

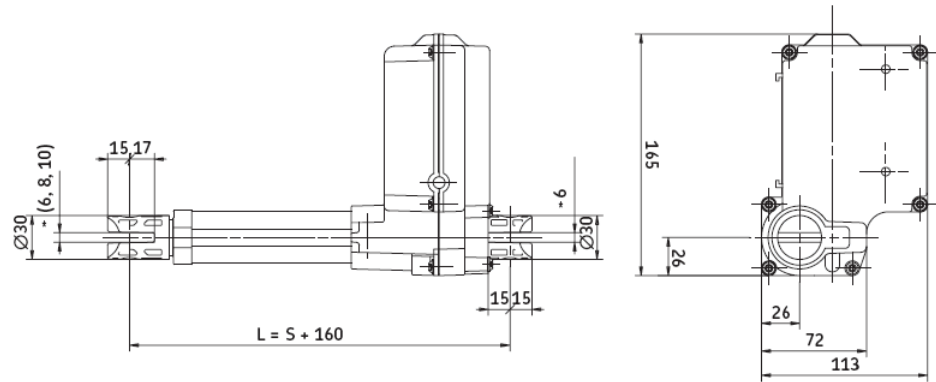

## Product information

Name: Ecomag

Designation: EC089-010MM1B0-000 ECOMAG



Legend:  
S = stroke  
L = retracted length

### Product specifications

Force pull	[N]	0
Force push	[N]	6 000
Housing		Small
Color		Grey
Motor type		24 VDC
Options		No
Current cut-off		No
Fork head		Hole diameter 12 mm, groove width 10 mm
Hinge		Hole diameter 12 mm, groove width 10 mm
Protection		IP X4S
Stroke	[mm]	100
Retracted length	[mm]	260
Speed at max. load	[mm/s]	4
Speed at no load	[mm/s]	7

www.linearmotion.skf.com

Please choose your country with the top menu